

VANA STAVILAR CU AX LIBER
SLUICE VALVE WITH FREE SHAFT

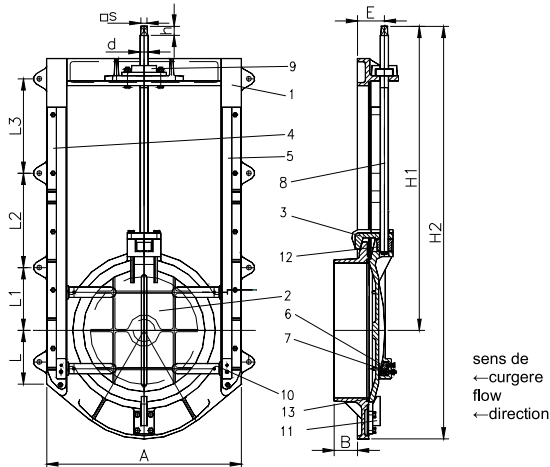

VANA STAVILAR CU COLOANA SI STALP DE MANEVARA
SLUICE VALVE WITH COLUMN AND PILLAR

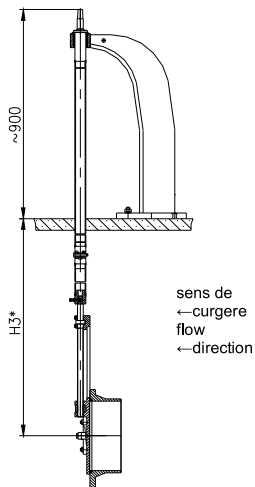

POZ. ITEM	REPER PART NAME	MATERIAL / MATERIAL	
		TIP TYPE	SIMBOL SYMBOL
1	Cadru / Frame	fonta cenusie / cast iron	EN-GJL-250
2	Disc inchidere Closing disc	fonta cenusie / cast iron	EN-GJL-250
3	Ghidaj sertar Wedge guide	fonta cenusie / cast iron	EN-GJL-250
		fonta nodulara ductile iron	EN-GJS-500-7
4	Ghidaj stanga Left guide	otel carbon/carbon steel	-
		fonta cenusie / cast iron	EN-GJL-250
5	Ghidaj dreapta Right guide	otel carbon / carbon steel	-
		fonta cenusie / cast iron	EN-GJL-250
6	Pana rolei Roll key	inox min.11,5%Cr min.11,5%Cr stainless steel	-
7	Surub reglare Adjusting bolt	inox min.11,5%Cr min.11,5%Cr stainless steel	EN-GJL-250
8	Tija / Stem	inox min.11,5%Cr min.11,5%Cr stainless steel	-
9	Presetupa / Gland	fonta cenusie / cast iron	EN-GJL-250
10	Rola+axul rolei Roll + roll shaft	inox min.17%Cr min.17%Cr stainless steel	-
11	Pinten / Spur	otel carbon / carbon steel	-
12	Piulita / Nut	aliaj Cu / copper alloy	-
13	Inel etansare Sealing ring	aliaj Cu / copper alloy	-
	Organe de asamblare Bolting	otel carbon / carbon steel	-

CARACTERISTICI CONSTRUCTIVE / DESIGN CHARACTERISTICS:

- constructie / design: - cu tija neascendentă / with non rising stem
- fixare în zidarie / mounting into the wall - cu tronson cilindric / with cylindric pipe section
- actionare / operation - cu tija liberă / with free shaft
- cu accesorii / with accessories: - roata de manevra / handwheel;
- coloana și stalp de manevra / column and pillar
- cu reductor / with gearbox
- adâncimea maximă de imersie / max. immersion depth - 5m la varianta cu coloana / 5m for variant with column ;
- tipul etansării / sealing type : - aliaj de Cu / fonta / copper alloy / cast iron
- aliaj de Cu / aliaj de Cu / copper alloy / copper alloy

TEMPERATURA MAXIMA DE LUCRU 60°C / MAX. WORKING TEMPERATURE 60°C

UTILIZARI PRINCIPALE / MAIN APPLICATION :

- în instalații de epurare și tratare a apelor, baraje, rezervoare, bazine, canale / in water treating plants, dams, tanks, basins, water troughs

MEDIUL DE LUCRU / WORKING FLUID:

- apă cu conținut de suspensii solide de max.10.000mg/l sau alte lichide necorozive față de materiale în contact cu mediul circulant / water with max.10.000mg/l solid particles content or other non corrosive fluids to the materials contacting

dimensiuni (mm.) / dimensions (mm.)

DN	A	B	C	E	H1	H2	L2	L1	h	s	Numar (rot/ cursa) Rotations no./stroke	Mom. actionare Torque daNm	Pierderi Leakage cm/min	Masa neta Net weight =(Kg.)	Varianta cu coloana si stalp de manevra / Variant with column and pillar	
															H3*	Masa / Weight =(Kg)
400	682	115	80	75	866	1208	106	438	33	22	80	10,5	200	140	2000	200
500	830	125	96	97	1176	1623	95	355			83	11,5	300	240	1800	259
600*	987	154	106	120	1354	1832	140	420	41	27	100	14	500	309	1400	355
700*	1125	180	106	130	1512	2011	172	484			116	15	600	450	3500	520
800*	1110	160	165	129	1775	2335	250	655	65	32	105	16	700	556	1850	605
900*	1210		152	130	1950	2560	280	682			116	17	850	649		710
1000*	1310		155	135	2130	2810	325	460/1190	80	32	116	18	850	803	4000	880
1200*	1510	165	140	2400	3220	445	550/675	46	46	135	20	900	1000	5000	1110	

H3* - cote standard. La cererea beneficiarului se pot asigura și alte valori / standard dimensions. On request can be offered others values.

* - produse la comandă / on request

Pentru confirmare va rugăm folosiți fișa tehnică contractuală / For confirmation please use the technical sheet of agreement FTC12