

DESCRIPTION: Three piece, full bore, cast steel body ball valve with AISI 304 ball and PTFE seat ring. BSPP female thread.

APPLICATION: Start/stop flow of: Compressed air, steam, gases and liquids. Typically also used for drain and vent purposes.

STANDARD & DESIGN:

Design Code: -
 Inspection Std.: -
 End Std.: ISO 228
 Face to Face Std.: -
 Top Flange: ISO 5211(DN8-DN100)
 Pressure rating: 1200 WOG(DN8-DN40)
 1000 WOG(DN50-DN100)

VARIATIONS: Various actuators.
 Other dimensions and materials on request.

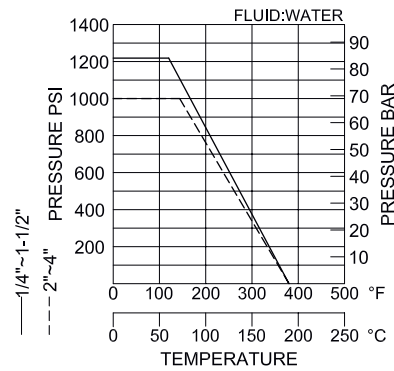
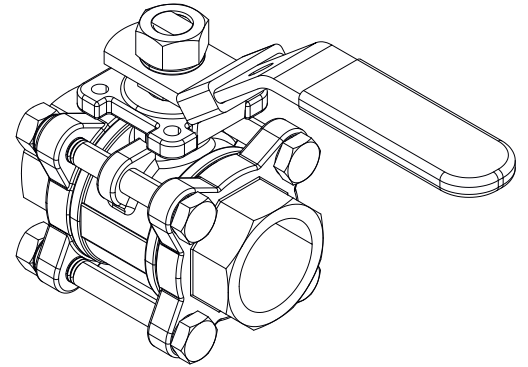

No	Part	Material	Code
1	Body	Cast Steel	ASTM-A216-WCB
2	Bonnet	Cast Steel	ASTM-A216-WCB
3	Ball	Stainless Steel	ASTM-A351-CF8
4	Ball Seat	PTFE	-
5	Stem	Stainless Steel	AISI 316
6	Joint Gasket	PTFE	-
7	Thrust Washer	PTFE	-
8	Stem Packing	PTFE	-
9	Gland Nut	Stainless Steel	AISI 304
10	Stem Washer	Stainless Steel	AISI 304
11	Stem Nut	Stainless Steel	AISI 304
12	Lock Device	Stainless Steel	AISI 304
13	Bolt	Stainless Steel	AISI 304
14	Spring Washer	Stainless Steel	AISI 304
15	Hex Nut	Stainless Steel	AISI 304
16	Stop Pin	Stainless Steel	AISI 304
17	Handle Cover	Plastic	-
18	Handle	Stainless Steel	AISI 430

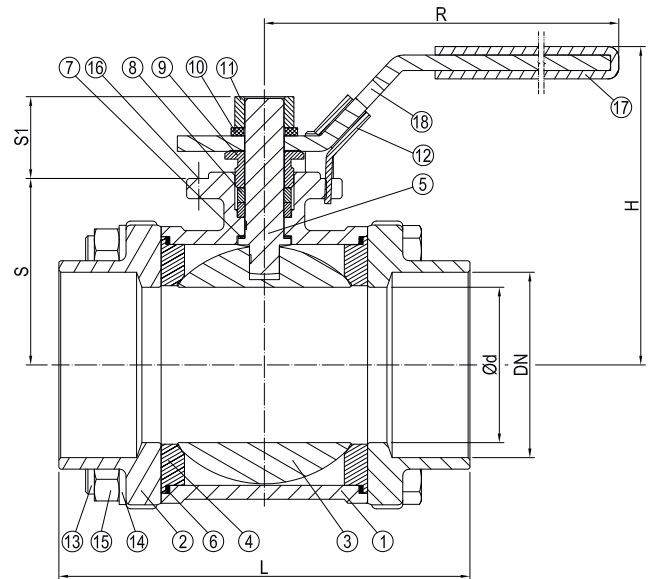

DN	Inch	L	H	ød	S	S1	R	Kg
8	1/4	58.2	55	11.6	26.5	13.3	95	0.4
10	3/8	58.2	55	12.7	26.5	13.3	95	0.4
15	1/2	62	60	15	30.5	15.8	95	0.5
20	3/4	76	63	20	33	18.3	110	0.7
25	1	85	79	25	39.5	21.5	135	1.1
32	1 1/4	100	86	32	43.5	23	135	1.6
40	1 1/2	115	94	38	52	25	165	2.4
50	2	132.2	103	50	62	23.1	165	3.4
65	2 1/2	165	133	65	77	41.2	285	6.9
80	3	183	144	80	90	39.7	285	11.7
100	4	231.4	177	100	110	47.1	295	22.2